

© 2022 Riawatech A/S. This document is subject to copyrights owned by Riawatech A/S. Any amendments, republication, retransmission, and/or reproduction of all or any part of the document is expressly prohibited, unless the copyright owner of the material has expressly granted its prior written consent. All other rights are reserved.

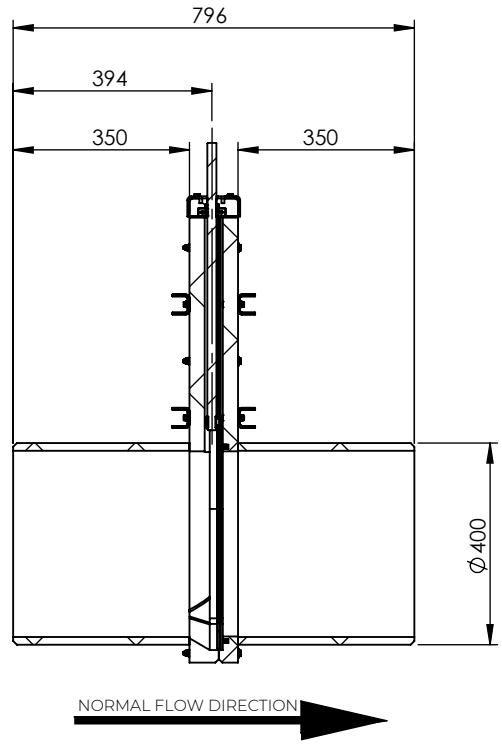

A-A

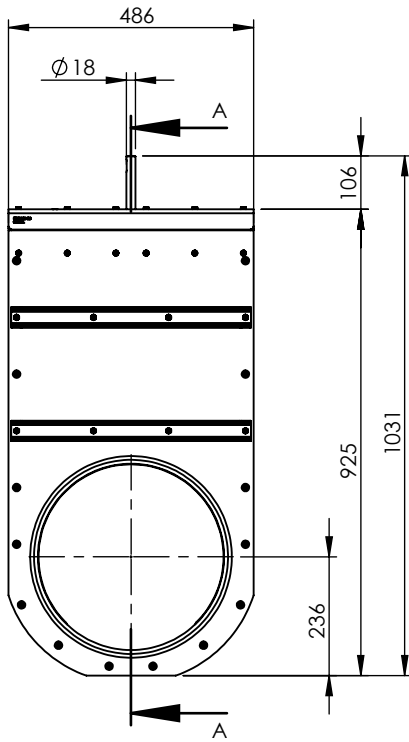
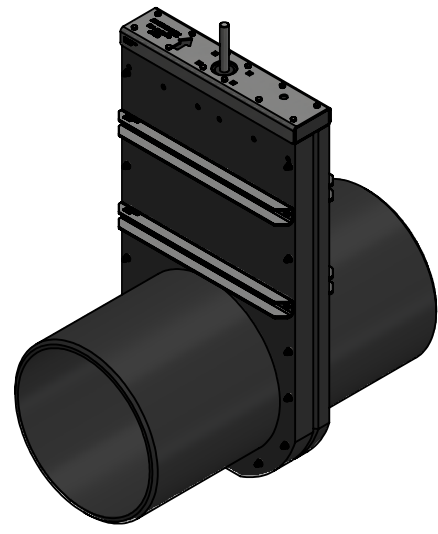
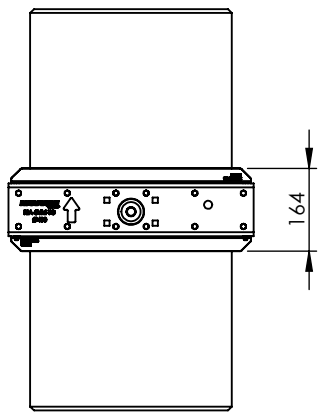

Approval Signature: _____

Date: _____

√	Article No.	Knife gate material	Spindle material	Reinforcement material
	V70076400	EN1.4404 / AISI 316	EN1.4404 / AISI 316	EN1.4404 / AISI 316
	V70078400	EN1.4462 / AISI 2205	EN1.4462 / AISI 2205	EN1.4404 / AISI 316
	V70079400	EN1.4462 / AISI 2205	EN1.4462 / AISI 2205	EN1.4462 / AISI 2205

Designed By PW	Approved By PW	Created Date 2022-08-30	Units [mm]	General Tolerance ISO 2768-1 m	Scale 1:15			
Material See table		Comment PE100 SDR17			Updated 2022-09-13			
Weight [kg] 68.15	Box Volume [m³]		Description SVM-TG Ø400					
 WAPRO GROUP www.riawatech.com			Stop Valve		Article Number See table	Drawing Number svm-tg-400_en	Rev A	Sheet 1 (1)